

PCD-400A/430A

Sensor Interfaces



The Carrier Wave Type Measuring Instrument Allows for Compactness and Low Prices

- Easy sensor connection using various types of input adapter
- Connects to PC using USB interface
- Measurement using 1 unit with 4 channels, up to a maximum of 4 units with 16 channels possible
- 4 unit simultaneous sampling using the connection connector set ST-1A (optional accessory)
- Simultaneous connection means simultaneous measurement of strain possible
- Dynamic data acquisition software (DCS-100A) standard accessory supporting Windows Vista, and Windows 7, Windows 8/8.1 (Japanese/English, 32/64 bit)
- Input adapter
 - Input adapter for strain gage transducer UI-10A (TEDS compatible)
 - Input adapter for strain gage UI-11A (TEDS compatible)
 - Input adapter for strain gage with operating lever UI-15A
 - One-touch lock type input adapter for strain gage UI-16A
 - One-touch type input adapter UI-55A (CE compatible)
 - Voltage input adapter UI-30A (for PCD-430A)
- Compact, lightweight
- Analysis of data using the analysis software (optional accessory) (DAS-200A) is possible.

*For details of data analysis software (DAS-200A), refer to P.4-9.

*For details of TEDS, refer to P.9-16.

*If 64 bit OS, operate in WOW64 (Windows 32-bit On Windows 64-bit) environment.

Connect the sensor interface to a PC via USB port. The PC will be a measuring instrument. Up to 4 units can be stacked for measurement in 16 channels.

PCD-400A specifications

Applicable sensor: Strain gage and strain gage transducer
Number of input channels: 4
Synchronous operation: A maximum of 4 units for 16 channels
Applicable gage resistance:
Quarter bridge 2-wire system, 3-wire system: 120Ω
Half bridge system, Full bridge system: 120 to 1000Ω
Input Connector: D-sub 37-pin connector
Bridge excitation: AC 2Vrms
Gage factor: Fixed at 2.00
Balance adjustment range: Resistance: Within $\pm 2\%$ (± 10000 m/m)
Within 5000 pF
Balance adjustment type: Resistance: Pure electronic auto balance system
Capacitance: CST method (automatic tracking)
Nonlinearity: Within $\pm 0.1\%$ FS
Range: 200, 500, 1000, 2000, 5000, 10000, and 20000 m/m – 7 steps
Accuracy: Within $\pm 0.5\%$ FS
Frequency response range: DC to 200 Hz, within deviation $\pm 10\%$
Sampling frequency: Maximum 10 kHz (Simultaneous 4-unit sampling for 16 channels at 10 kHz)
Low-pass filter: 2nd Butterworth
Cutoff frequency: 10, 30, 100 Hz, and flat – 4 steps
Amplitude ratio at cutoff point: $-3\text{dB} \pm 1\text{dB}$
Attenuation: $-12 \pm 1\text{dB/oct.}$
AD convert: 24-bit
Setting value retention: The range and balance adjustment value etc. are written to nonvolatile memory.
TEDS function: Reads the sensor TEDS information
(Input adaptor: UI-10A and UI-11A only)
Channel name writing
(If the manufacturer's ID is Kyowa)
Interface: USB2.0 (Conforms to High-Speed USB standards. Can also be operated in a USB3.0 port.)
Stability: Temperature
Zero point: Within ± 0.2 m/m/°C
Sensitivity: Within $\pm 0.05\%$ /°C
Time
Zero point: Within ± 1 m/m/8h
Sensitivity: Within $\pm 0.3\%$ /8h
Withstand voltage: 250 VAC for 1 minute between input and chassis,
Operating temperature humidity range: 0 to 40°C
20 to 85% RH (Noncondensing)
Vibration resistance: $\pm 29.42\text{m/s}^2$ (3G)
5 to 200 Hz (12 cycles for each axis, 10 minutes/cycle)
Power supply: 11 to 16 VDC
Connector type: RM12BRD-4PH (Hirose)
Consumption current: 0.7A or less (12 VDC)
External dimensions: 210 (W) x 35 (H) x 157.5 (D) mm (excluding protrusions)
Weight: Approx. 700 g
EMC directive: EN61326-1 (Class A)
RoHS directive: EN50581



DATA RECORDERS/ANALYZERS

Sensor to recommend

Strain Gages



Encapsulated Strain Gages



Load Cells



Pressure Transducers



Acceleration Transducers



Torque Transducers



Displacement Transducers



Voltage





Standard Accessories

USB cable N-38 (1m)
Ground wire P-72 (5m)
(Dynamic data acquisition software DCS-100A)

Optional Accessories

AC adaptor UIA345-12
USB cable N-39 (2m)
DC power cable P-76 (DC 11 to 16V, 2m)
Connection cable N-97 (10cm)
Stacking connector set (ST-1A)
Stack fixture (CN-20)
Input adaptors (At least one is required)
Input adapter for strain gage transducer UI-10A (TEDS supported)
Input adapter for strain gage UI-11A (TEDS supported)
Input adapter for strain gage with operating lever UI-15A
One-touch lock type input adapter for strain gage UI-16A
One-touch type input adapter UI-55A

PCD-430A specifications

Comprehensive specification
Number of Channel: 4
Synchronous Measurement: Up to 4 units by 16 channels
Input Connector: 37-pin D-sub connector
Sampling Frequency: Maximum 10 kHz (simultaneous sampling of 4 units 16 channels)
A/D Converter: 24 bits
Holding Setting Condition: Range, Balance adjustment are stored in internal nonvolatile memory.
TEDS Function: Loading function from the TEDS sensor CH name writing function (For the manufacture ID: KYOWA only)
Interface: USB2.0(Compliant to the High-Speed, USB3.0 port supported)
Operating Temperature & Humidity Range: 0 to 40°C, 20 to 85% RH (Noncondensing)
Vibration Proof: ±29.42m/s ² (3G), 5 to 200 Hz(12 cycles for each axis, 10minutes/cycle)
Power Supply: 11 to 16 VDC Connector: RM12BRD-4PH (Hirose)
Consumption Current: 0.9 A or less (12 VDC)
Dimensions: 210(W) × 35(H) × 157.5(D)mm (not including Protrusions)
Weight: Approximately 750 g
EMC directive : EN61326-1 (Class A)
RoHS directive : EN50581

Standard Accessories

USB cable N-38 (1m)
Ground wire P-72 (5m)
(Dynamic data acquisition software DCS-100A)

Optional Accessories

AC adapter UIA345-12(For 1 to 4)
USB cable N-39 (2m)
DC power cable P-76 (11 to 16 VDC, 2m)
Connection cable N-97 (10cm)
Stacking connector set (ST-1A)
Stack fixture (CN-20)
Input adaptors (At least one is required)
Input adapter for strain gage transducer UI-10A (TEDS compatible)
Input adapter for strain gage UI-11A (TEDS compatible)
Input adapter for strain gage with operating lever UI-15A
One-touch lock type input adapter for strain gage UI-16A
One-touch type input adapter UI-55A
Voltage input adapter UI-30A

Strain Measuring Mode
Measuring Target: Strain gage, Strain Gage Transducer
Input Form: Balanced Differential Input
Applicable Gage Resistance: Quarter bridge system (2-wire and 3-wire) : 120 ohm Half bridge system : 120 to 1000 ohm Full bridge system : 120 to 1000 ohm
Bridge Excitation: 2VAC _{rms}
Gage Factor: 2.00 Fixed
Balance Adjustment Range: Resistance: Within ±2%(±10000 μm/m) Capacity: Within 5000 pF
Balance Adjustment method: Resistance: Auto balance Capacity: CST method (automatic tracking)
Nonlinearity: Within ±0/1% FS
Range: 200,500,1 k, 2 k, 5 k, 10 k, and 20 k μm/m - 7 steps Accuracy: Within ±0.5% FS
Frequency Response range: DC to 200 Hz, deviation within ±10%
Low Pass Filter: 2nd Order Butterworth Cutoff frequency: 10, 30, 100 Hz, and FLAT - 4 steps Amplitude ratio at cutoff point:-3 ±1 dB Attenuation characteristics:-12 ±1 dB/oct.
Stability: Temperature Zero point: ±0.2 m/m/°C Sensitivity: ±0.05%/°C Time Zero point: ±0.5 μm/m/8h Sensitivity: ±0.15%/8h
Withstand Voltage: Input-case, 250 VAC, 1 min.
Voltage Measuring Mode
Measuring Target: Voltage
Input Form: Unbalanced Input
Range: 1, 2, 5, 10, 20, and 50 V - 6steps Accuracy: Within ±0.2% FS
Frequency Response range: DC to 1 kHz, Deviation Within -3 to +1 dB
High Pass Filter: 2 steps of 0.2 Hz, OFF
Low Pass Filter: 2nd Order Butterworth Cutoff frequency:10, 30, 100, 300 Hz and FLAT - 5steps Amplitude ratio at cutoff point:-3 ±1 dB Attenuation:-12 ±1 dB/oct
Stability: Temperature Zero point: ±0.008%FS/°C Sensitivity: ±0.02%/°C Time Zero point: ±0.03%FS/8h Sensitivity: ±0.1%/8h

Sensor to recommend

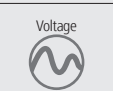
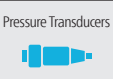

Connect a strain gage and a PC using a USB cable to start measurement

Tensile test of materials

Stress measurement while mounting the printed board

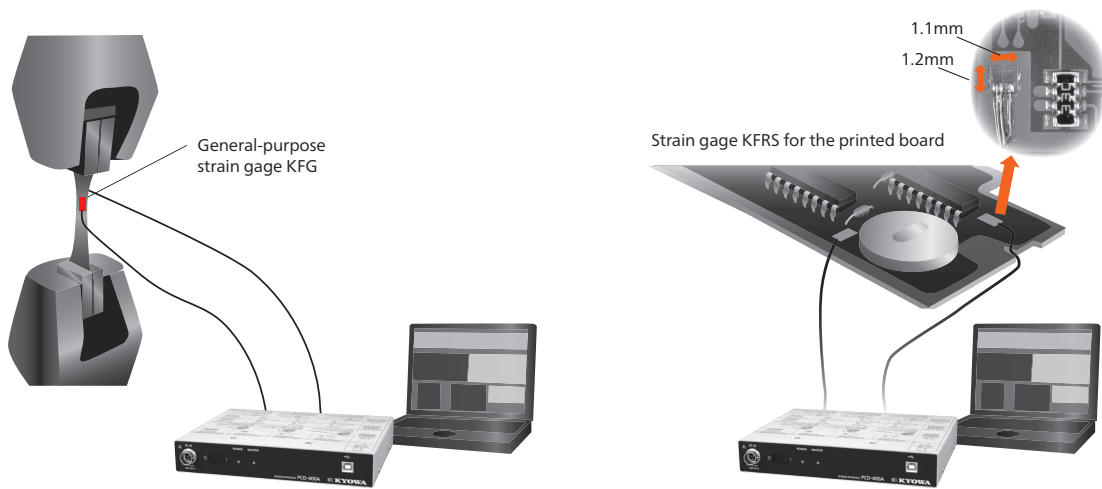

Since the configuration is simple, measurement can be easily started in any place if you have a sensor, a PC, and this product

Evaluation test of materials

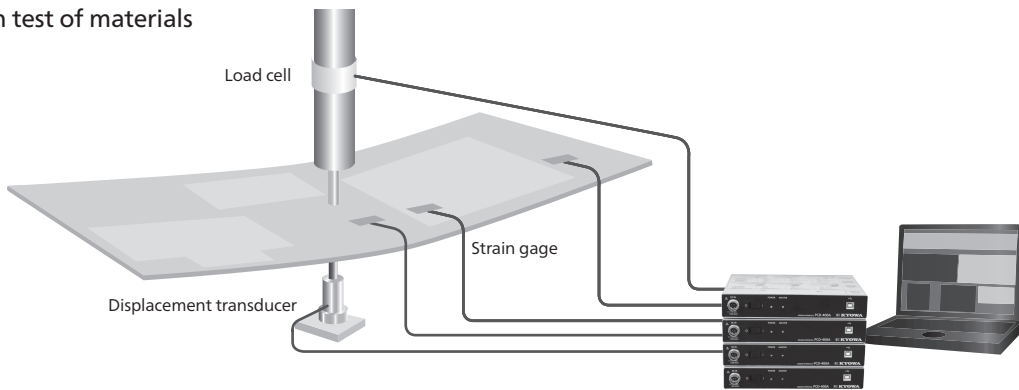

■ Dimensions

PCD-400A/430A (Figure is PCD-400A)

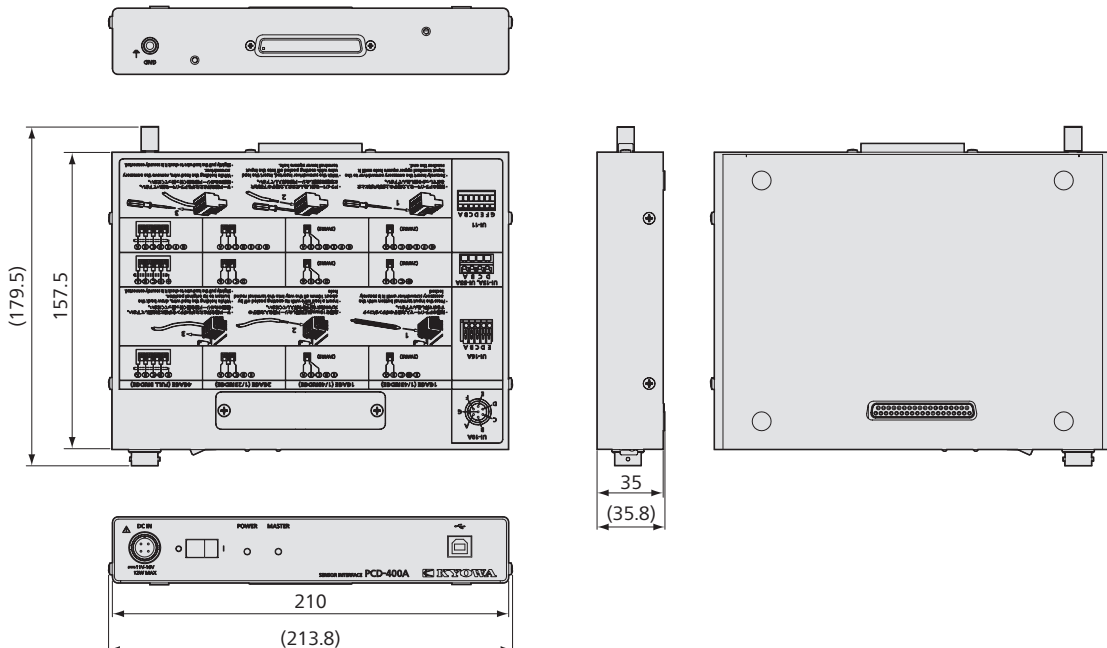

- Sensor to recommend
- Strain Gages
- Encapsulated Strain Gages
- Load Cells
- Pressure Transducers
- Acceleration Transducers
- Torque Transducers
- Displacement Transducers
- Voltage

● Input adapter

- Input adapter for strain gage transducer UI-10A (TEDS support) (With NDIS standard connector)

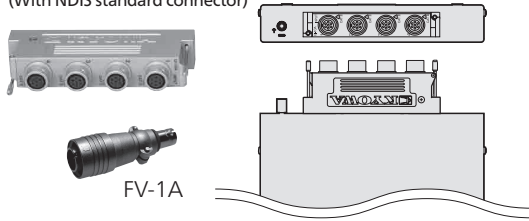

- Input adapter for strain gage UI-11A (TEDS support)

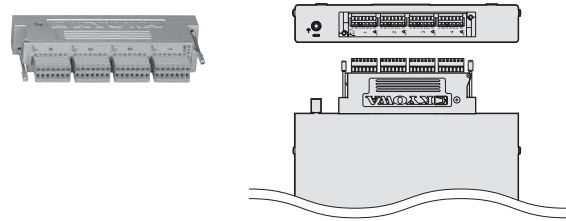

- Input adapter for strain gage with operating lever UI-15A

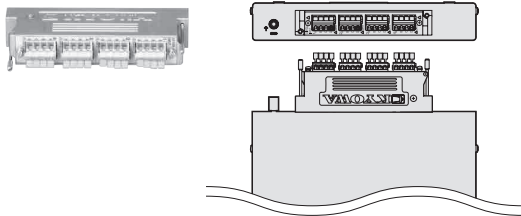

- One-touch lock type input adapter for strain gage UI-16A

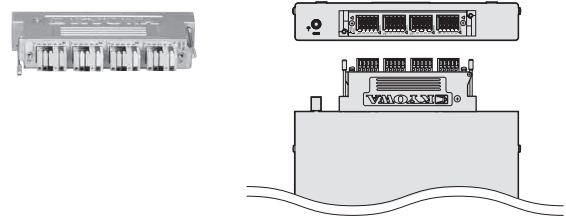

- Voltage input adapter UI-30A

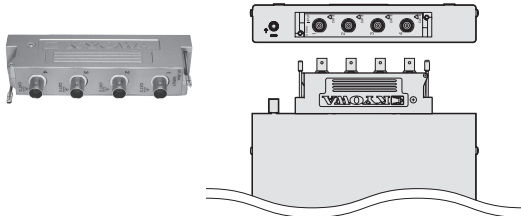

- One-touch type input adapter UI-55A (CE support)

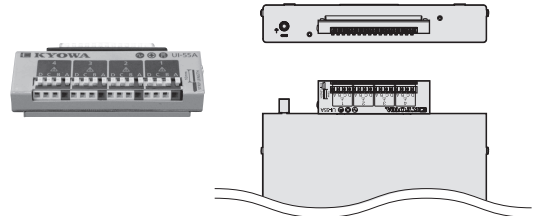

Connection cable N-97

Use when connecting a transducer to the UI-11A, UI-15A, and UI-16A connector plug.

DCS-100A software control specification

OS : Windows Vista, Windows 7, Windows 8/8.1, Japanese/English, and 32/64-bit correspondence
Operates in the Windows 32-bit On Windows 64-bit environment
Number of measuring units : Maximum of 4 (maximum of 16 channels)
Interface : USB2.0 (Conforms to High-Speed USB standards. Can also be operated in a USB3.0 port.)
Data acquisition : Measurement data is saved on the PC hard disk (in KS2 files).
Channel conditions : Measurement ON/OFF, strain mode, range, low-pass filter, balance ON/OFF, calibration factor, offset, gage factor, unit, channel name, measurement range, number of decimals, rated capacity, rated output, upper value check, lower value check, offset zero ON/OFF (any display item selectable)
Sampling frequency : 1 to 10 kHz (1/2/5 systems)
Measurement mode : "Manual," "Manual" (specifying the amount of acquired data), "Interval," "Analog trigger"
Manual measurement : Data is acquired between REC and STOP or until the amount of the acquired data specified is reached after REC.
Interval measurement : Data acquisition is automatically performed after settings are made for the start time and acquisition interval.
Analog trigger measurement : Data acquisition is started/ended under preset trigger conditions.
Trigger conditions
End trigger : Settings possible
Delay : For start/end, a maximum of 640,000 bits of data/ 1 channel. * The amount of delay differs depending on the number of channels measured.
Trigger channel : Any 1 channel
Trigger level : Setting by physical quantity
Trigger slope : Rising edge/falling edge

Static measurement : Each time data acquisition is started, measurement data processed using a moving-average model is added to and saved as a CSV file. * Workable in "manual" or "interval" mode
Repetition acquisition : In long-term data acquisition, a specified amount of data is saved in KS2 file at specified intervals. * Workable in manual mode (with the amount of acquired data specified)
Environmental settings
Hardware configuration settings : Settings for the unit name and unit Unit name settings possible on the PCD-400A Number of connected units readable from the PCD-400A
Automatic data file conversion : Automatic file conversion upon the termination of measurement (CSV, XLS, XLSX, and RPC III formats)
Random unit settings : The user can register three available units at random.

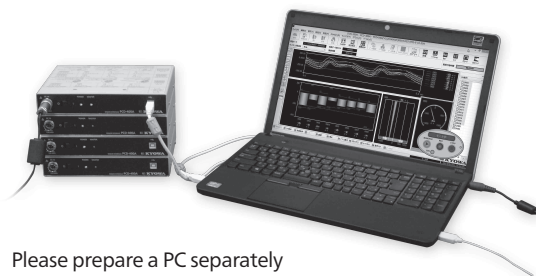

Please prepare a PC separately

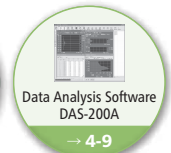

Sensor to recommend



Encapsulated Strain Gages



Load Cells



Pressure Transducers



Acceleration Transducers



Torque Transducers



Displacement Transducers

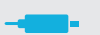

Voltage

